

BRANIFF

WATER SOLUTIONS

Model

▪ AUDAZE SQUARE UNDER-MOUNT LAV

▪ 52820020.B

LAVATORY

| Features

- Lavatory Style: Under-Mount Lav
- Material: Vitreous China
- Color: White
- Average Weight: 15.04 lbs
- Discharge hole diameter: 1 3/4"



| Specifications

- ASME A112.19.2-2018/CSA B45.1-18



| Components



#	Description	Code	QTY
1	Audaze Square Under-Mount Lav	L3A02A	1

10 Years Warranty on Vitreous China |

| Technical Data

Section	Measures
A	16 ¼ "
B	13 "
C	16 ¼ "
D	13 "
E	Ø 1 ¾ "
F	8 ¾ "
G	8 ¾ "

* Dimension tolerance of ±5%

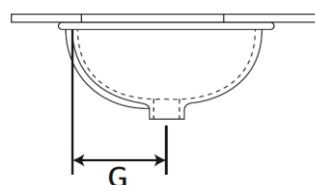
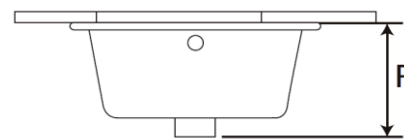
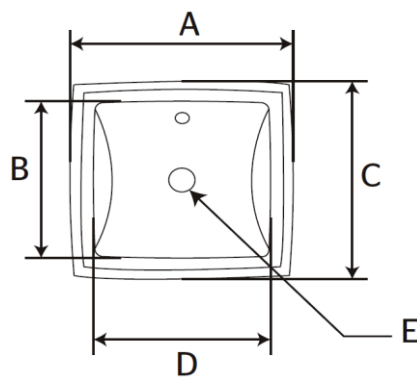

All dimensions are in inches (in)

| Instalation

The sink must be placed under the previously sectioned furniture or surface.

| Recomendations

- Before selecting any mixer, it is recommended to verify that it is compatible with the design of the lavatory.
- The ceramic is fragile and may break during manipulation, gloves are recommended during installation.
- Use antifungal silicone sealant for the joints of the lavatory with the surface, don't use cement or adhesive plaster.
- When installing the fixing screws, take care not to exceed the tightening force of the nuts, as this can break the ceramic.
- Hand tighten the supply hose (not included) to the mixer, if there is any leak, lightly tighten with a tool, don't use any type of sealant in the joints.

| Maintenance

- Do not leave ceramic for long periods of time without cleaning.
- Do not clean with ammonia or acids, as it will irreversibly damage the ceramic finish, just use soap and a sponge.
- Clean the surface with a soft damp cloth, adding non-abrasive detergent cleaner if required, dry off.

| Warranty

All products commercialized by BRANIFF are designed, manufactured and tested accordingly to our quality system and to international standards if any manufacturing or workmanship defect were to be presented on the product and corroborated by BRANIFF, it will be replace it without cost to buyer. Finishes are warranted against manufacturing defects for 10 (ten) years on vitreous china.

10 Years Warranty on Vitreous China |